

ISO 9001
CERTIFIED

shindaiwa®

OWNER'S AND
OPERATOR'S MANUAL

SOUND PROOF DIESEL
ENGINE
GENERATOR/WELDER

DGW201M

Vertical, Water-Cooled
4-Cycle Diesel Engine

Table of Contents	Page
1.Safety Guidelines	2
2.Specifications	5
3.Use	5
4.Parts	6
5.Equipment	7
5-1.Monitor Lamp	7
5-2.Throttle	9
5-3.Circuit Breaker	10
5-4.Slow-Down	10
6.Initialization and Pre-check	10
6-1.Checking Engine Oil	10
6-2.Checking Coolant/Water	11
6-3.Checking Fuel	12
6-4.Checking Fuel, Engine Oil and Water Leakage	12
6-5.Checking Battery	13
7.Operation	13
7-1.Start up	14
7-2.Stopping	15
8.Welding Operation	15
8-1.Selection-Welding Cable	15
8-2.Polarity	16
8-3.Connection-Welding Cable	16
8-4.Duty Cycle	16
8-5.Welding	17
9.Generator Operation	18
9-1.Operation	18
9-2.Output Limitation	19
10.Simultaneous Use of Welding and Generating	20
11.Checking and Maintenance	21
12.Long-term Storage	26
13.Troubleshooting	26
14.Engine Wiring Diagram	28
15.Generator Wiring Diagram	29





CAUTION: Do not operate the Generator/Welder, or any other appliance, before you have read and understood the instructions for use.

Introduction

Thank you for purchasing Shindaiwa Sound Proof Diesel Engine Generator/Welder.

- This user manual was created to ensure the safe operation of this equipment. Therefore, the manufacturer of this equipment strongly recommends that the user follow the instructions herein, to avoid unnecessary accidents and repairs.
- Please operate this equipment after thoroughly reviewing and understanding the contents of this manual.
- Please attach this manual, if the equipment will be sub-leased.
- Please store this manual near the equipment for easy reference.

■ Following convention will be used throughout the manual to indicate the degree of cautions.

 Danger	<i>Can cause serious injuries or death.</i>
 Caution	<i>Can cause minor injuries or damage to the equipment or other properties.</i>
<Caution>	<i>Other types of caution</i>

- Even some of the items noted in 『 **Caution**』 may lead to serious injuries. Please read all item and follow all the safety guidelines.

1. Safety Guidelines

Danger : Suffocation from exhaust fume

- Exhaust fume from the engine contains many elements harmful to human. Do not operate this equipment in poorly ventilated area, such as inside a room or in a tunnel.

Danger : Electric Shock

- Do not operate the equipment, if the equipment or you are wet.
- Do not insert metal objects (such as pin or wire) into plug-in receptacles.
- Do not touch wiring or electric parts inside the equipment during operation.
- Before connecting or disconnecting a welding cable from output terminals, stop the engine, and remove the engine key.
- Before performing any equipment check or maintenance, stop the engine, and remove the engine key. A person performing the check or maintenance should always keep the key.

Danger : Burns

- Do not open the radiator cap while operating this equipment or immediately after stopping the equipment, to avoid sustaining burns from hot vapor.

Danger : Injuries

- Close all doors and place locks during operating this equipment, to avoid injuries by unintentionally touching cooling fan and fan belt.

Caution : Suffocation from exhaust fume

- Do not point the exhaust fume toward pedestrians or building.

Caution : Suffocation from welding fume

- Be sure to wear a fume proof mask in operation, because welding fume contains poisonous gas and dust. Pay attention to the airflow direction and sufficient ventilation also in order to prevent from inhaling the fume.

Caution : Injuries to eyes and skin

- Be sure to wear spark protection glass(es), long-sleeve shirts, gloves, etc. in order to protect eyes and skin from harmful spark in welding.
- Battery fluid contains diluted sulfuric acid. Avoid contact with eyes, skin or on clothing. If the acid comes in contact, especially with eyes, flush with a lot of water, and contact to your physician immediately.

Caution : Electric shock

- Do not flush water onto the equipment nor operate it in the rain.

Caution : Explosion

- When the liquid level is below the LOWER level, never use the equipment nor recharge the battery.
- Battery may emit some combustible gas, so keep it away from fire and sparks.

⚠ Caution : Fire

- The equipment uses Diesel fuel as a fuel. When refueling, always stop the engine and keep away from fire. Moreover, always wait until the engine cools down before refueling.
- Always wipe any drip of Diesel fuel or lubrication oil. Do not use this equipment when a leak is found. Repair the equipment before use.
- Temperature around muffler and exhaust can get extremely high. Keep any inflammable items (such as fuel, gas, paint, etc.) away from the equipment.
- Keep any inflammable items and easily burning items away from the place in welding, because welding splashes spatters.
- Always operate this equipment on flat surface and, at least 1 meter away from any objects (wall, box, etc.).
- Do not connect AC output to any indoor wiring.
- Always wait until the equipment cools down, before placing any covering materials for storage.

⚠ Caution : Burns

- Do not touch the engine and muffler during operation and immediately after stopping the equipment, for the temperature can reach extremely high.
- When checking engine oil or changing oil, always stop the engine, and wait until the engine cools down. If you open either the oil gauge or the oil plug during operation, hot oil may cause some injury.
- Be sure to wear leather gloves, apron, shoe covers, eye protection glass(es) (mask), safety shoes, safety cap, and long sleeve shirts, because welding splashes spatters.
- Do not open the side panel during operation and immediately after stopping the equipment, because some parts/components (flexible tube, resistors, etc.) can reach very high temperature inside the equipment.

⚠ Caution : Injuries

- When lifting the equipment, always use a lift hook. Do not lift a handle, for it may cause equipment to drop due to handle breaking off.
- Always place the equipment on a flat and stable surface, to keep the equipment from sliding. Be sure to lock the wheels for the wheeled models.
- When starting the engine, turn off the connected equipment and set the circuit breaker to OFF position.
- Do not move the equipment during operation.
- When performing equipment check and maintenance, always stop the engine.
- Do not operate the equipment, if the equipment is being modified or if the parts are removed.

■ Location of Warning labels

When the warning labels become unreadable or damaged, place new labels on the appropriate locations, as specified in the following figure.

When ordering the label, use the following part numbers.

- ① Suffocation from exhaust fume (No. 19402-00194)
- ② Suffocation from welding fume (No. 19402-00195)
- ③ Burns (No. 19402-00200)
- ④ Electric shock (No. 19402-00193)
- ⑤ Injuries (No. 19402-00199)
- ⑥ Burns (No. 19402-00201)

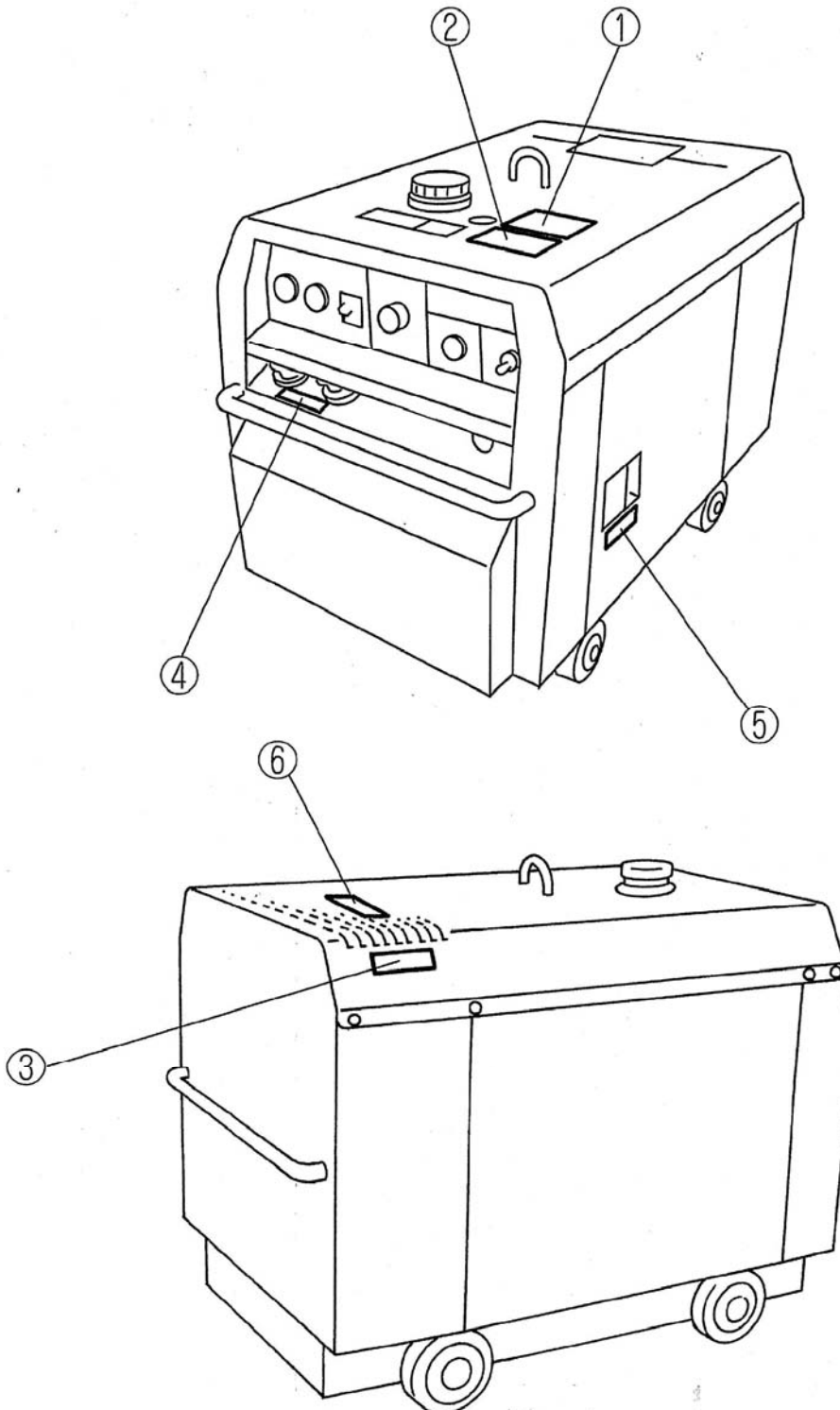

2. Specifications

Model		DGW201M
Generating Method		Rotating Field, Synchronous AC Generator
Welding Generator	Rated Current (A)	170 / 190
	Rated Voltage (V)	26.8 / 27.6
	Duty Cycle (%)	50
	Rated Speed (min ⁻¹)	3000 / 3600
	No Load Voltage (V)	MAX 80
	Current Adj. Range (A)	60 – 180 / 50 - 200
	Welding Rod (Φ)	2.0 - 4.0
AC Generator	Rated Frequency (Hz)	50 / 60
	Rated Speed (min ⁻¹)	3000 / 3600
	Phase	1-Phase
	Rated Voltage (V)	220
	Power Factor	1.0
	Rated Current (A)	13.6 / 15.9
	Rated Output (kVA)	3.0 / 3.5
	Rating	Continuous
Engine	Model	Kubota Z482-B
	Type	Vertical, Water-Cooled 4-Cycle Diesel Engine
	Displacement (L)	0.479
	Rated Output (kW/min ⁻¹)	7.8 / 3000 or 9.2 / 3600
	Fuel	ASTM No.2 Diesel Fuel or Equivalent
	Lubricant Oil	API Class CD or Higher
	Lubrication Oil Volume (L)	2.05 (Effective 0.7)
	Cooling Water Volume (L)	2.8 (Sub Tank Capacity 0.6 L included)
	Starting Method	Starter Motor
Battery		44B19L
Fuel Tank Capacity (L)		About 15
Dimension	Length (mm)	998
	Width (mm)	603
	Height (mm)	773
Dry Weight (kg)		212

3. Use

- Arc Welding
- Power Source for electric tools and home appliances
- Power Source for lights

⚠ Caution : Damage to the equipment or other properties

- The equipment is designed for the above purposes only. Do not use it for the other purpose. When it will be used for the equipment with the microcomputers control or for the ultra-precision devices, the load may be malfunctioned.

4. Parts

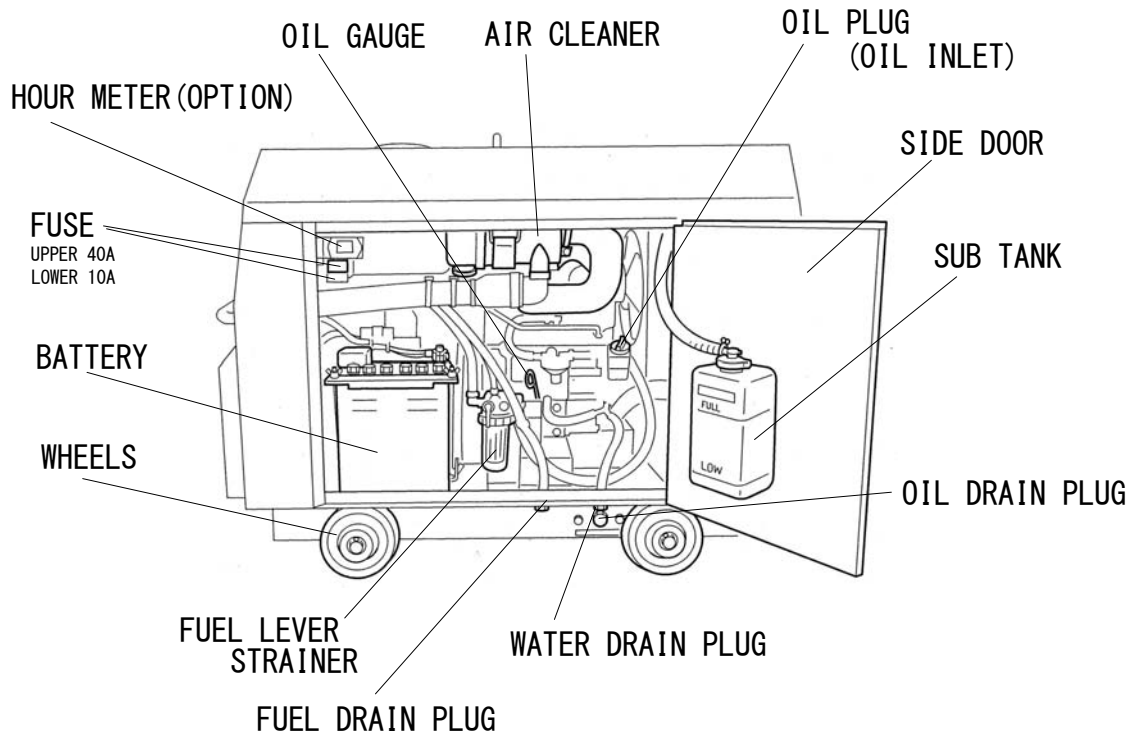
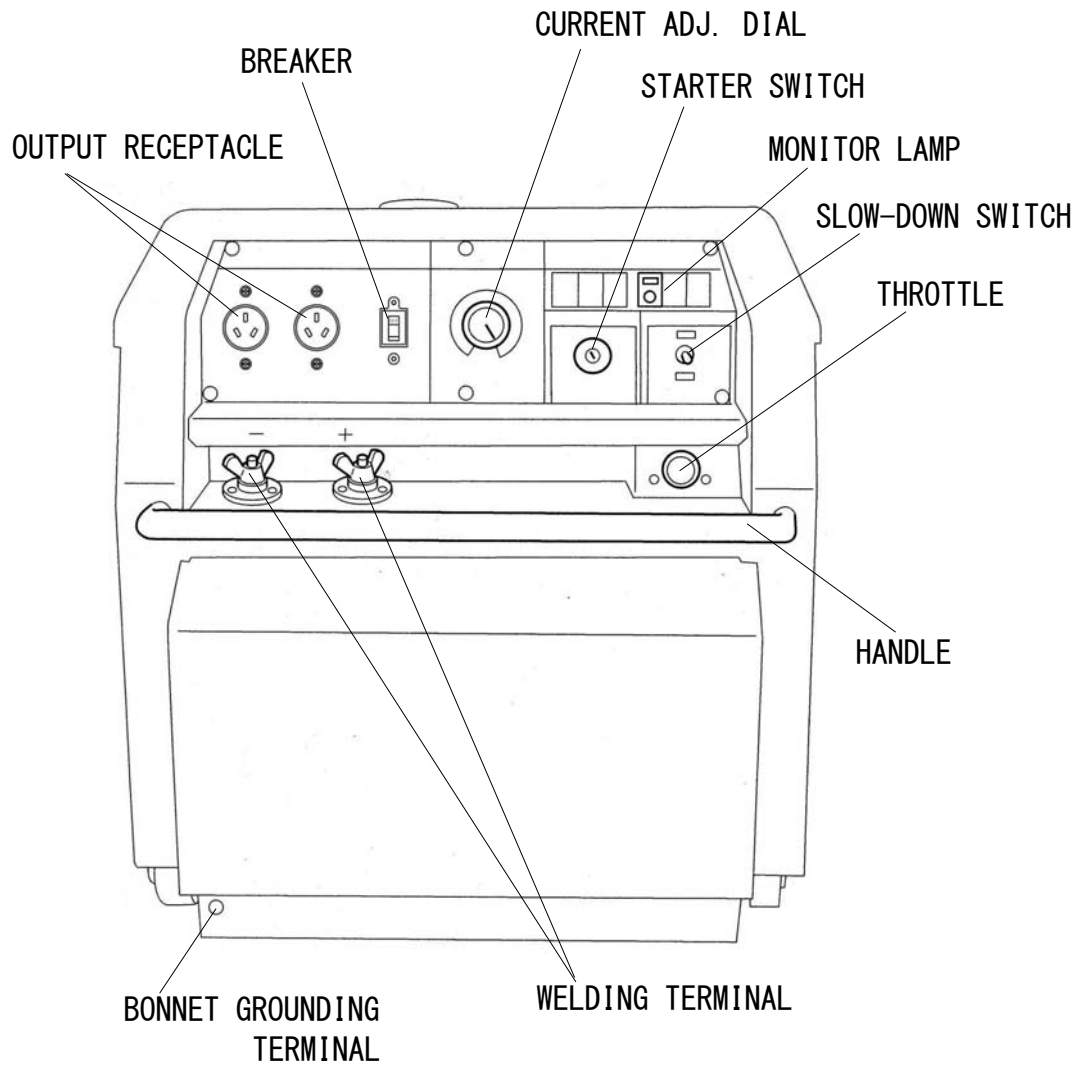

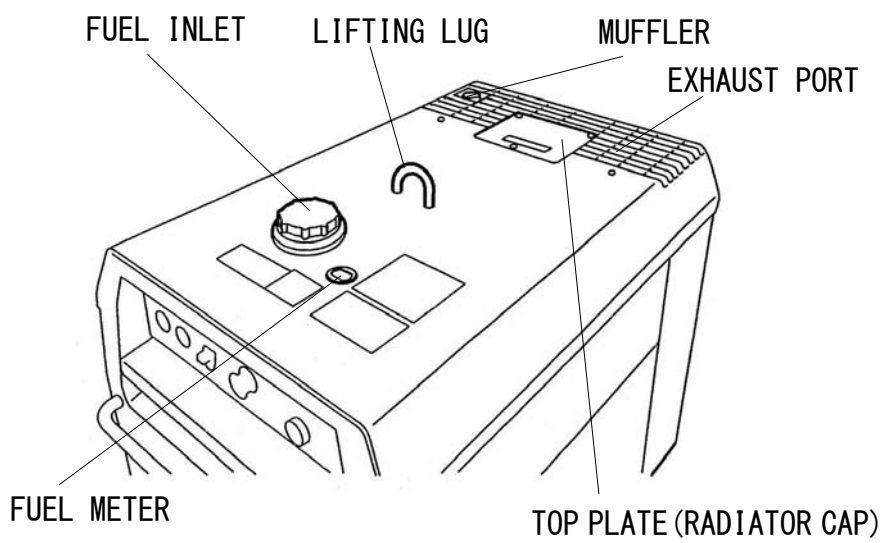
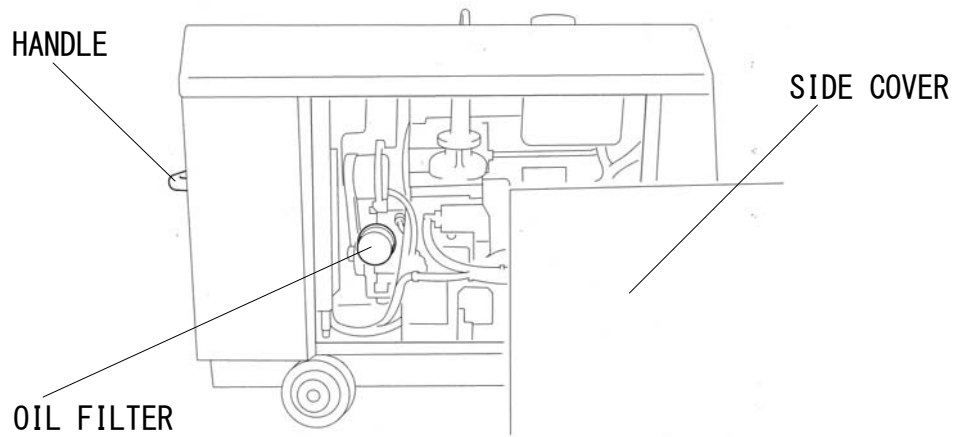

5. Equipment

5-1. Monitor Lamp

The equipment is equipped with monitoring function of Oil Pressure, Battery Charge and Water/Coolant Temperature.

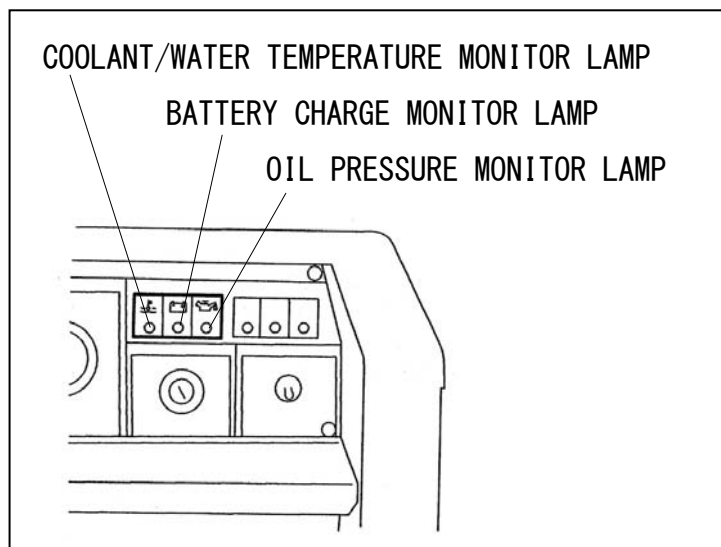

When it is started by the starter switch from STOP to RUN under normal condition, Oil Pressure and Battery Lamps will flash, and then the lamps will go OFF, immediately after the engine starts.

When abnormality is detected either in water temperature or in oil pressure, the correspondent monitor lamp will flash, and the automatic shutoff shall be engaged to the engine.

When the automatic shutoff is engaged, turn the starter switch to STOP position, and then restart the engine. In the event the automatic shutoff is engaged next time, check all parts of the correspondent alarm.

(1) Oil Pressure Monitor Lamp

Danger : Injuries

- Close all doors and place locks during operating this equipment, to avoid injuries by unintentionally touching cooling fan and fan belt.

Caution : Burns

- Do not touch the engine and muffler during operation and immediately after stopping the equipment, for the temperature can reach extremely high.
- When checking engine oil, always stop the engine, and wait until the engine cools down. If you open either the oil gauge or the oil filter cap during operation, hot oil may cause some injury.

When the engine oil pressure drops during operation, the oil pressure monitor lamp will flash, and the automatic shutoff will be engaged.

When this occurs, check the engine oil level, and replenish to the maximum level if needed.

<Caution>

- The engine oil pressure monitor cannot detect the degradation of engine oil itself. Please check the engine oil periodically, and change if needed.
(Refer to 『11. Maintenance』)

(2) Battery Charge Monitor Lamp

When the battery is unable to be charged during operation, the battery charge monitor lamp flash and the automatic shutoff will be engaged. In the event it will happen, consult with the authorized distributor or our engineering section.

<Caution>

- The battery charge monitor cannot detect the degradation of the battery nor the battery fluid level. Check the battery fluid level periodically.
(Refer to 『6-5. Checking Battery』)

(3) Coolant/Water Temperature Monitor Lamp

⚠ Danger: Injuries

- Close all doors and place during operating this equipment, to avoid injuries by unintentionally touching cooling fan and fan belt.

⚠ Danger: Burns

- Do not open the radiator cap while operating this equipment or immediately after stopping the equipment, to avoid sustaining burns from hot vapor.

⚠ Caution: Burns

- Do not touch the engine and muffler during operation and immediately after stopping the equipment, for the temperature can reach extremely high.

When the water temperature rises abnormally, the coolant/water temperature monitor lamp will flash, and the automatic shutoff will be engaged.

When this occurs, check the coolant/water reservoir tank, and replenish if needed.

(Refer to 『 6-2. Checking Coolant / Water 』)

If the water level is normal, there may be a possibility of overloading and always use equipment within the rated amperage.

<Caution>

- In the event coolant/water level is too low to detect, the sensor does not monitor temperature. Be sure to check the level in the sub tank before operation.
- Check the fuse next, after oil pressure, battery charge and water temperature will be found normal. If the fuse is burned out, consult with our authorized distributor or our engineering section, because there may be an abnormality of electric/electronic parts or wiring and repairing may be required.

5-2. Throttle

The device is to select the output in conformity with the application. You can save fuel consumption and lower noise by selecting [low speed welding/50Hz].

Throttle	Low Speed Welding 50Hz	Welding AC 220V	170A Duty Cycle 50% 50Hz 3.0kVA
	High Speed Welding 60Hz	Welding AC 220V	190A Duty Cycle 50% 60Hz 3.5kVA

<Caution>

- Before turning the throttle, be sure to confirm that engine has stopped or at the slow-down speed where the slow-down switch positions [ON].

5-3. Circuit Breaker

⚠ Danger : Injuries

- Be sure to turn off the power switch in the load when re-turning the circuit breaker to ON, in case the circuit breaker has activated.

In case the electric supply exceeds the rated output (overload), the circuit breaker activated to trip off in order to shut off the circuit. When the load stops during operation, check the breaker first of all. If you will find the breaker positions at OFF, recover it by the following procedures.

- ① Turn off all the power switches in the loads.
- ② Return the breaker to ON.

<Caution>

- Refer to 『 9-2. Output Limitation 』 and be careful not to use overloaded (over current)

5-4. Slow-Down

The slow-down feature is to set the engine speed low automatically (in about 8 seconds) for the purpose of reducing noise and fuel consumption, whenever welding operation or generating operation is not performed. In case of using the slow-down feature, turn the slow-down switch to ON

The engine automatically moves to high speed when welding or electric supply starts.

⚠ Caution : Damage to the equipment or other properties

- Always turn the slow-down switch to OFF in case the load is incorporated with electro magnetic switch.

<Caution>

- In case the load of less than 0.5A is connected to use, the slow-down feature does not function sometimes. Therefore, turn the switch to OFF.
- When welding operation or electric supply is used intermittently, turn the switch to OFF.

6. Initialization and Pre-check

⚠ Caution : Fire · Burns · Injuries

- When checking engine, always stop the engine, and keep away from fire. Wait until the engine cools down, before performing any checks.

6-1. Checking Engine Oil

When checking for engine oil, be sure to keep the equipment leveled, and insert the oil gauge all the way in.

Prior to starting the equipment, make sure to fill the engine oil to the HIGH level through the oil inlet.

Oil Volume: about 2.0L (Total)

Effective Oil Volume: about 0.7L

(from the lower limit to higher limit)

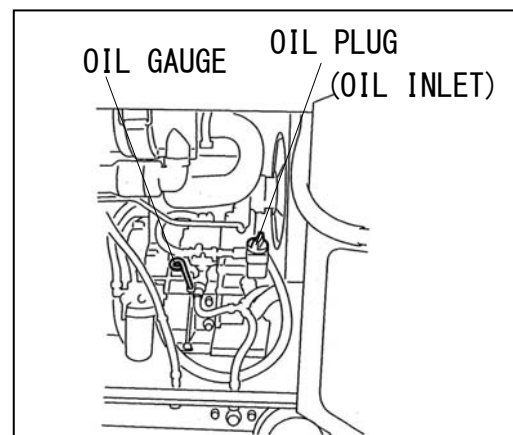

<Caution>

- If the equipment is not leveled, you cannot obtain accurate oil level.
- Do not overfill (over H line) the engine oil. The excessive volume of engine oil may damage the engine.

- Selecting proper engine oil
Use the engine oil for Diesel engine in proper viscosity, in compliance with the ambient temperature (Refer to the chart).

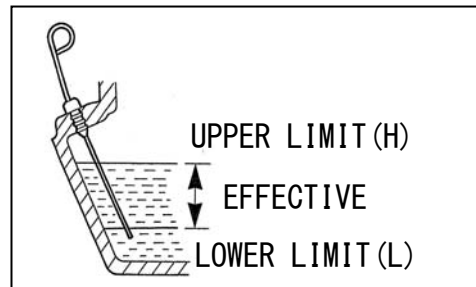

<Caution>

- Use the API class CD or higher.

Viscosity and Temperature

Temperature	Over +20°C	+10~+20°C	-10~+40°C
Viscosity	SAE30	SAE20	SAE10W/30

6-2. Checking Coolant / Water

⚠ Danger : Injuries

- Close all doors and place locks during operating this equipment, to avoid injuries by unintentionally touching cooling fan and fan belt.

⚠ Danger : Burns

- Do not open the radiator cap while operating this equipment or immediately after stopping the equipment, to avoid sustaining burns from hot vapor.

⚠ Caution : Burns

- Do not touch the engine and muffler during operation and immediately after stopping the equipment, for the temperature can reach extremely high.

Check to see if the coolant/water level is between FULL and LOW levels in the sub tank. If the coolant/water is below the LOW level, fill the tank and the radiator accordingly.

(1) Filling to the Sub Tank

- ① Remove the sub tank cap.
- ② Fill up the sub tank to the FULL level.
- ③ Install the cap back.

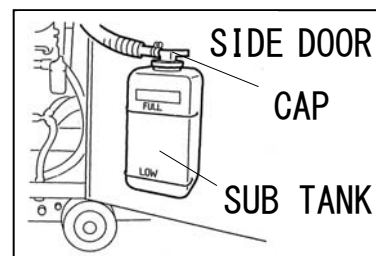

(2) Filling to the Radiator

- ① Remove the top plate.
- ② Remove the radiator cap.
- ③ Fill up the radiator up to the top.
- ④ Install the cap back and tighten.
- ⑤ Reinstall the top plate.

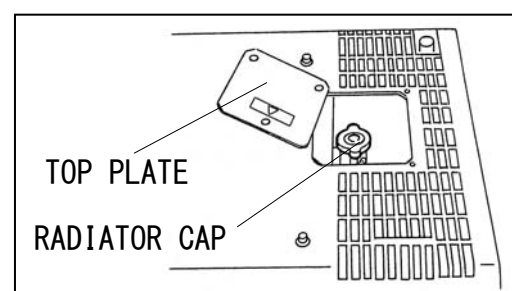

<Caution>

- Use soft water, such as tap water.
- If the ambient temperature is near freezing, use Long Life Coolant(LLC) (30% mixture LLC is filled when shipped from factory)
- Mixture ratio of the coolant should be 30%-45%, depending on the ambient temperature.
- Use the same LLC to the sub tank.
- Replace LLC at every 2 year or 2000 hours.

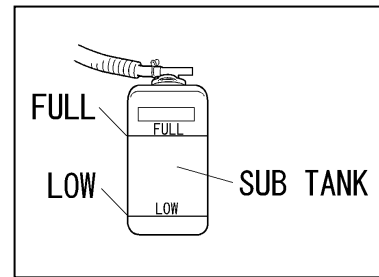

LLC Maximum Mixture Ratio

Lowest Ambient Temperature	-15°C	-20°C	-30°C
Max Mix. Ratio	30%	35%	45%

6-3. Checking Fuel

⚠ Caution : Fire

- Always wipe any drip of fuel. Do not use this equipment when a leak is found. Repair the equipment before use.

Check for the fuel level in the tank. Add if necessary.

<Caution>

- Use Diesel fuel, ASTM D975 No.2-D in the event ambient temperature reaches down to -5°C.
- At the temperature less than -7°C, No.2 D fuel may pose operating problem. At colder temperature, use No.1-D fuel (if available) or use “winterized” No.2-D (a blend of No.1-D and No.2-D).
- Always use the fuel strainer.
- Fill the fuel tank slightly less than the ring level.

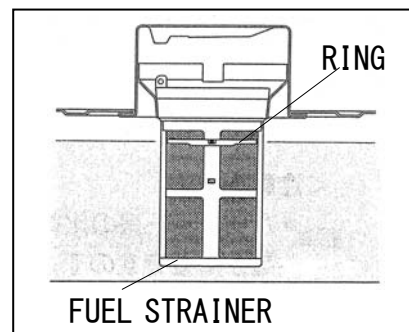

6-4. Checking Fuel, Engine Oil and Water Leakage

⚠ Caution : Fire

- Always wipe any drip of Diesel fuel or oil. Never use this equipment when a leak is found. Repair the equipment before use.

Be sure to check for any fuel leak at hose connection, and oil and coolant/water by opening side doors. When checking for fuel leak, open a fuel lever and be sure to close the fuel lever after checking.

6-5. Checking Battery

⚠ Caution : Injuries to eyes and skin

- Battery fluid contains diluted sulfuric acid. Avoid contact with eyes, skin or clothing. If the acid comes in contact, especially with eyes, flush with a lot of water, and contact to your physician immediately.

⚠ Caution : Explosion

- When the liquid level is below the LOWER level, never use the equipment nor recharge battery.
- Battery may emit some combustible gas, so keep it away from fire and sparks.

⚠ Caution : Fire

- Battery may emit some combustible gas, so keep it away from fire and sparks.

- ① Check the fluid level. If the level is near or lower than LOWER level, add distilled water until the fluid level reaches UPPER level.
- ② Make sure that the battery cables are firmly secured to the posts. Tighten the clamps if necessary.

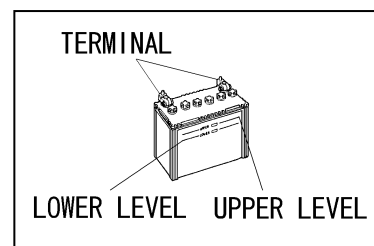

<Caution>

- Check the hydrometer of the battery fluid. If it falls below 1.23, the battery requires recharging. Please consult with our authorized distributor or our engineering section.

■ Replacing battery

- ① Remove the clamp and cable from negative (-) post in the battery. (Remove always negative side first)
- ② Remove the hold-down clamp from the battery.
- ③ Remove the clamp and cable from positive (+) post in the battery.
- ④ Remove the battery from the seat.

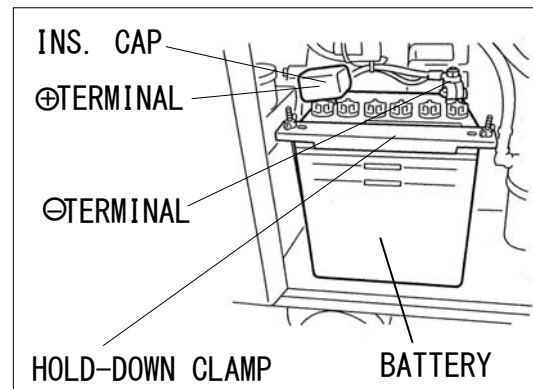

- ※ Reinstall a new battery in the reverse order.
(Install always the cable to the positive (+) post in the new battery first.)

<Caution>

- Use the following battery.
44B19L

7. Operation

⚠ Danger : Suffocation from exhaust fume

- Exhaust fume from the engine contains many elements harmful to human. Do not operate this equipment in poorly ventilated area, such as a room or in a tunnel.

⚠ Caution : Suffocation from exhaust fume

- Do not point the exhaust fume toward pedestrians or building.

⚠ Caution : Fire

- Temperature around muffler and exhaust can get extremely high. Keep any inflammable items (such as fuel, gas, paint, etc.) away from the equipment.
- Always operate this equipment on flat surface and, at least 1 meter away from any objects (wall, box, etc.)

⚠ Caution : Injuries

- Always place the equipment on flat and stable surface, to keep the equipment from sliding. Be sure to lock the wheels for the wheeled models.
- When starting the engine, turn off the connected equipment and set the circuit breaker to OFF position.

7-1. Start up

- ① Turn the circuit breakers to OFF position.
 - ② Turn the fuel lever to OPEN.
 - ③ Turn the Slow-Down switch to ON.
 - ④ When the ambient temperature is below 5°C, turn the starter switch to PREHEAT. The lamp comes off when the preheating finished in about 5 seconds.
 - ⑤ Turn the starter switch to START to start the engine by the starter motor.
- <Caution>
- Do not drive the starter motor for more than 15 seconds successively.
 - If you need to restart, wait for 30 seconds or more before retry.
- ⑥ Release the starter switch, as soon as the engine is started.
- <Caution>
- Once the engine is started, do not turn the starter switch to START.
- ⑦ Keep the engine idle for about 5 minutes.

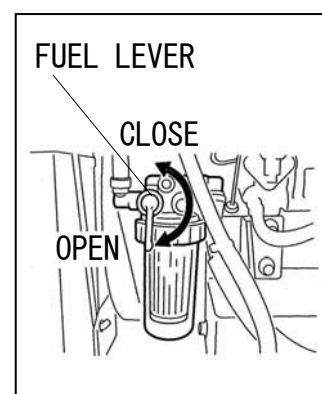
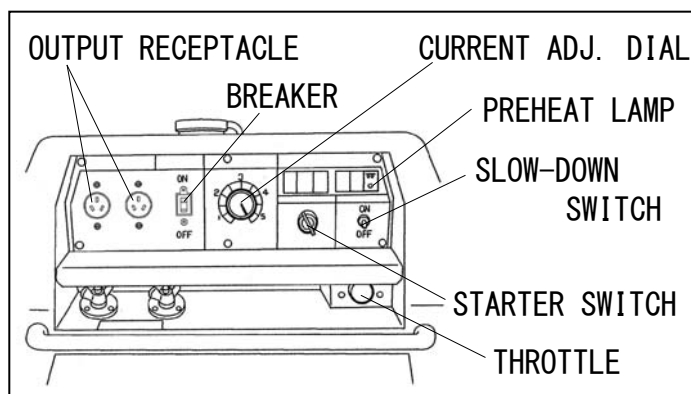

■ Restart after stopping due to fuel shortage

This equipment is equipped with automatic air vacuuming feature. Therefore, even though the engine stops due to out of fuel, you can restart the engine easily by the following steps.

- ① Turn the starter switch to STOP.
- ② Fill the fuel.
- ③ Turn the Slow-Down switch to ON.

- ④ Turn the starter switch to RUN (Operation).
- ⑤ Turn the starter switch to START and drive the starter motor in about 10 seconds.

<Caution>

- Do not drive the starter motor for more than 15 seconds successively.
- If you need to restart, wait for 30 seconds or more before retry.

- ⑥ Release the starter switch, as soon as the engine is started.

<Caution>

- Once the engine is started, do not turn the starter switch to START.

- ⑦ Wait for about 1 minute to vacuum the air out.
(The engine speed becomes stable when the air is extracted.)

<Caution>

- Keep the Slow-Down switch ON until the air is completely extracted out (until the engine speed becomes stable), otherwise the engine may disorder.

7-2. Stopping

- ① Turn (Push-down) the breaker to OFF.
- ② Turn the Slow-Down switch to ON.
- ③ Keep the engine idle (cooling down) for about 5 minutes.
- ④ Turn the starter switch to STOP.
- ⑤ After the engine stops, turn the fuel lever to CLOSE.

<Caution>

- When the engine does not stop in spite of turning the starter switch to STOP, turn the fuel lever to CLOSE, the engine will stop in a few minutes.
In this case, consult with our authorized distributor or our engineering section and ask repair.

8. Welding Operation

8-1. Selection – Welding Cable

Select the cable with proper gauge, based on the allowable amperage and distance, per the table shown below.

The welding capacity is to reduced if the small gauge cable is used.

<Caution>

- Welding cables should be used unstrained.
- When the welding cables are used in swirl, the welding capacity is reduced.

Proper size of cable (Unit: mm²)

Return Length Welding Current	Proper size of cable (Unit: mm ²)					
	20m	30m	40m	60m	80m	100m
200A	22	30	30	50	60	80
150A	22	22	22	38	50	60
100A or below	22	22	22	22	30	38

8-2. Polarity

There are two kinds welding output terminals, 『+』 and 『-』 .

Select the polarity according to the operation, referring to the table below.

<Caution>

- Follow the instruction of the welding rods, the polarity of which is specified.

	Application	Connection
Normal Polarity	Generals Welding for construction material	Plus to the Earth (Material) Minus to holder (Rod)
Reverse Polarity	Thin Plate, Build-Up , Stainless Steel	Plus to holder (Rod) Minus to the Earth (Material)

8-3. Connection – Welding Cable

⚠ Danger : Electric Shock

- Before connecting or disconnecting a welding cable from welding output terminals, stop the engine, and remove the engine key. A person performing should always keep the key.

- ① Stop the engine.
- ② Connecting a welding cable to a crimping terminal and a welding rod holder, and connect the other cable to a crimping terminal and a material holder.
- ③ Connect the welding cables to the welding output terminals.

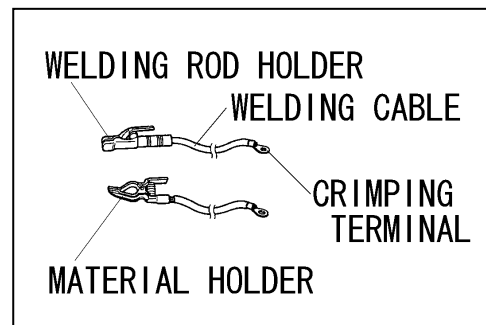

<Caution>

- Be sure to crimp a crimping terminal to a cable and connect the cable to welding output terminal. Otherwise, welding output terminals may burn out by the heat caused by insufficient connections.
- Do not use a cable without a crimping terminal. If you use the cable, the insulation is peeled off partly, to bind to an output terminal, the output terminal may burn out by the heat caused by insufficient connections and also a bare part of the cable may touch the bonnet to short-circuit.

8-4. Duty Cycle

Duty cycle means the welding time ratio for 10 minutes. The duty cycle of the equipment is 50%, namely, the welding time is 5 minutes or less in continuous 10 minutes. Be sure to take 5 minutes recess after 5 minutes welding.

<Caution>

- The equipment may be damaged due to overheat, if welding in more than successive 5 minutes or short time recess.

8-5. Welding

⚠ Caution : Suffocation from welding fume

- Be sure to wear a fume proof mask in operation, because welding fume contains poisonous gas and dust. Pay attention to the airflow direction and sufficient ventilation also in order to prevent from inhaling the fume.

⚠ Caution : Injuries to eyes and skin

- Be sure to wear spark protection glass(es)(Refer to the table below) , long-sleeve shirts, gloves, etc. in order to protect eyes and skin from harmful spark in welding.

Light Shielding Standard Glass (Japan Industrial Standard)

Light Shielding Degree No.	7	8	9	10	11	12	13
Welding Current (A)	30-75		76-200		201-400		

⚠ Caution : Fire

- Keep any inflammable items and easily burning items away from the place in welding, because welding splashes spatters.

⚠ Caution : Burns

- Be sure to wear leather gloves, apron, shoe covers, eye protection glass(es)(mask), safety shoes, safety cap and long sleeve shirts, because welding splashes spatters.

After engine is started (Refer to 『 7-1. Start up 』), operate as per the following procedures.

- ① Turn the Slow-Down switch ON.
- ② Turn the throttle either to [Low Speed Welding 50Hz] or [High Speed Welding 60Hz].

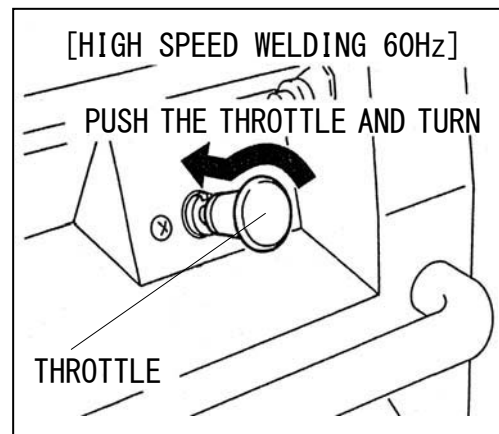
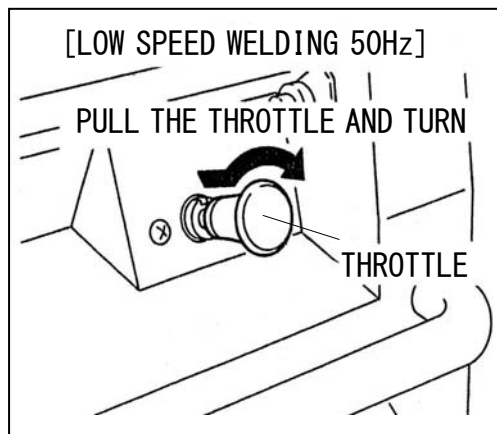

- ③ Adjust the current by the current adjustment dial.
The adjustable current range is different from the throttle position., [Low Speed Welding 50Hz] and [High Speed Welding 60Hz].

Welding Current Adjustable Range

Throttle Position	Current Adjustable Range	Welding Rod
Low Speed Welding 50Hz	60-180A	φ 2.0 – φ 4.0mm
High Speed Welding 60Hz	50-200A	φ 2.0 – φ 4.0mm

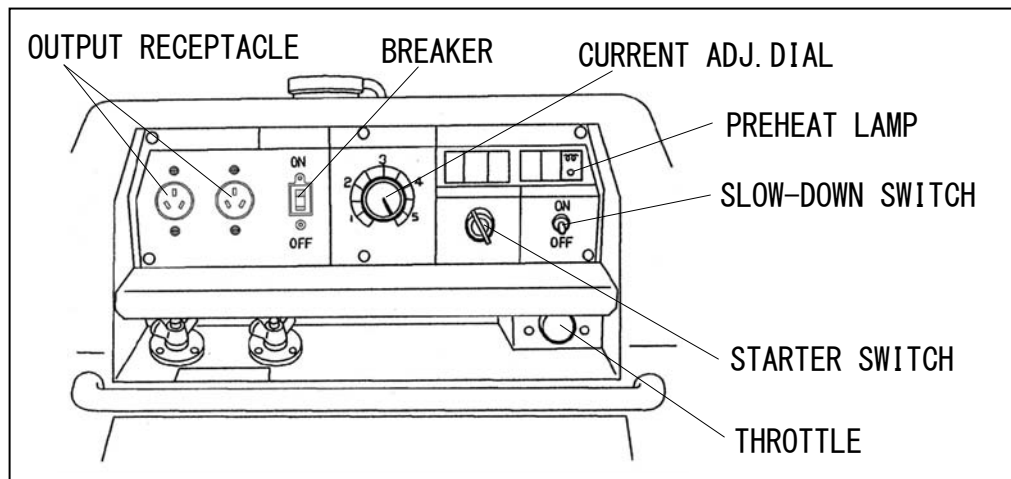

9. Generator Operation

⚠ Danger : Electric Shock

- Do not operate the equipment, if the equipment or you are wet.

⚠ Caution : Injuries

- Before connecting or disconnecting a load cable from output terminals, always turn a circuit breaker to [OFF] position.
- Be sure to use the frequency designated in the load.
(Refer to 『 5-2. Throttle 』)

⚠ Caution : Damage to the equipment or other properties

- In the event using the equipment to computers, microcomputers incorporated loads and precision equipment, there is a possibility for them to be mal-functioned or break down.
- Be sure to use the frequency designated in the load.
(Refer to 『 5-2. Throttle 』), otherwise the load may be damaged.

<Caution>

- Maximum output current from 15A receptacle is 15A.
- Total output current from 2 receptacles is as follows.
Rated Output 50Hz: 13.6A
60Hz: 15.9A

9-1. Operation

After engine is started (Refer to 『 7-1. Start up 』), operate as per the following procedures.

- ① Turn the Slow-Down Switch [ON].
- ② Select the frequency.
50Hz: Pull the throttle and turn
60Hz: Push the throttle and turn
- ③ Turn the breaker [ON].
By the above procedures, you can use 220V AC power from receptacles.

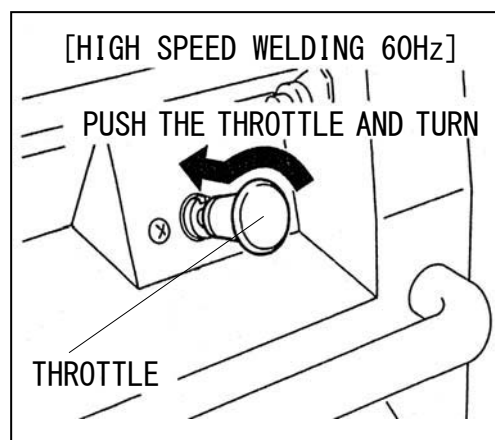
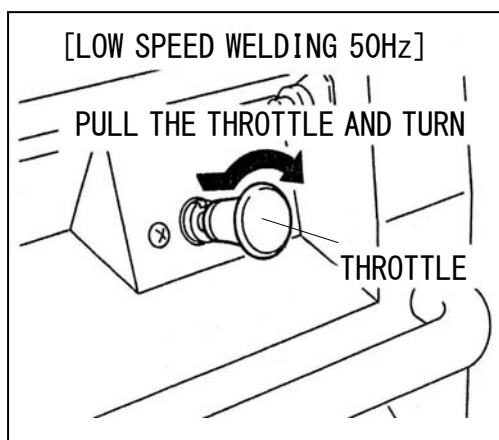
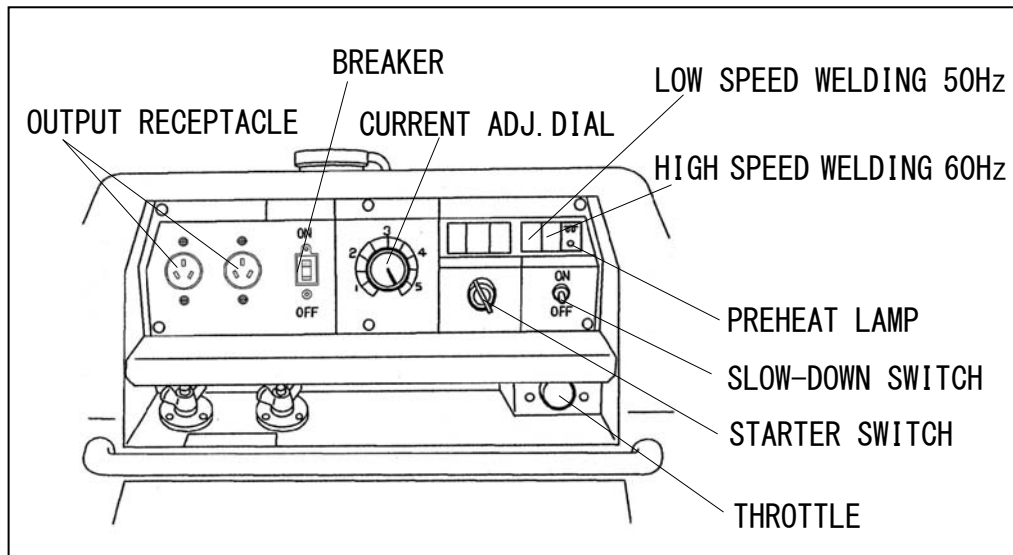

9-2. Output Limitation

Please refer to the following table, because electric tools and home appliances cannot be judged only by the rated output or the power consumption due to the efficiency and character of the components.

Applicable Load (For reference only)

Loads	Capacity (kW)	
	50Hz	60Hz
Electric Bulb, Heater, etc.	3.0	3.5
Electric Tools, etc (Series Motor),	1.5	1.7
Mercury Bulb (High Power Factor Type)	1.2	1.4
Submersible Pump, Compressor, etc (Induction Motor)	1.2	1.4

- ※ Series Motor : Motor with brush
- ※ Induction Motor : Brushless Motor
- ※ The value shown above is 『Output Power』 in Induction motor and 『Consumption Power』 in other equipment.

<Caution>

- Be sure to use the frequency designated in the load incorporated in mercury bulb or induction motor.

- The load incorporated in motor may require bigger power than the rated power consumption. Therefore, consult with our authorized distributor or our engineering section .
- When connecting to use 2 sets or more to use, start the load one by one, not to start them simultaneously.
- When switching a Mercury bulb again, wait for 15 minutes (about) until it cools down.
- A mercury bulb may flicker.

10. Simultaneous Use of Welding and Generating

The circuit breaker reacts on the AC power supply circuit only. In the simultaneous use of welding and generating, there sometimes happens overload to the engine.

Refer to the following Supply in the simultaneous use of welding and generating
(For reference only as a kind of rod may require more current)

Welding Output Welding Rod / Current	AC Power Output	
	50Hz	60Hz
ϕ 2.0mm/60A	3.0kVA or below	3.5kVA or below
ϕ 2.6mm/100A	2.5kVA or below	3.0kVA or below
ϕ 3.2mm/140A	1.0kVA or below	1.5kVA or below
ϕ 4.0mm/170A	0.5kVA or below	0.5kVA or below

11. Checking and Maintenance

Danger : Electric Shock • Injuries

- Before performing any equipment check or maintenance, stop the engine, and remove engine key. A person performing the maintenance should always keep the key.

Danger : Burns

- Do not open the radiator cap while operating this equipment or immediately after stopping the equipment, to avoid sustaining burns from hot vapor.

Caution: Fire • Burns

- Keep the equipment far away from fire.
- When checking engine, always stop the engine, and keep away from fire. Wait until the engine cools down, before performing any checks.
Do not touch the engine and muffler immediately after stopping the equipment, for the temperature can reach extremely high. Wait until the engine cools down before performing any checks

Caution : Injuries to eyes and skin

- Battery fluid contains diluted sulfuric acid. Avoid contact with eyes, skin or clothing. If the acid comes in contact, especially with eyes, flush with a lot of water, and contact to your physician immediately.

Caution : Explosion

- When the liquid level is below the LOWER level, never use the equipment nor recharge battery.
- Battery may emit some combustible gas, so keep it away from fire and sparks.

Caution : Fire

- Battery may emit some combustible gas, so keep it away from fire and sparks.

<Caution>

- The authorized technicians should perform all checking and maintenance work, except for the pre-startup checks.
- Request for the maintenance item with ● mark to the authorized distributor or our engineering section.
- Always use our genuine parts of replacement.

To optimize the use of this generator/welder, we recommend the periodical equipment checks and maintenance based on the following matrix.

Use the hour meter as a guide for the operating time.

Checking Items	Start up Check	Checking Time					
		At 50hrs	Every 100 hrs	Every 200 hrs	Every 400 hrs	Every 1000 hrs	Every 2000 hrs
1	Check and Supply Fuel	○					
2	Check and Supply Engine Oil	○					
3	Engine Oil Change		1 st ○	2 nd or after ○			
4	Oil Filter Change		1 st ○		2 nd or after ○		
5	Check/Add Water/Coolant	○					
6	Water/Coolant Change						○ or 2 years
7	Clean Fuel Strainer		1 st ○	2 nd or after ○			
8	Change Fuel Filter					○	
9	Drain Water/Clean Fuel Tank				○		
10	Check Leakage Fuel, Oil, Water	○					
11	Check/Add Battery Water	○					
12	Clean Air Element		1 st ○	2 nd or after ○			
13	Change Air Element					○	
14	Adjust Tension V-Belt		1 st ●	2 nd or after ●			
15	Change V-Belt					● or 2 years	
16	Clean Radiator Fin					●	
17	Check Carbon Brush					●	
18	Clean Radiator (inside)					●	
19	Change Fuel Hose, Oil Hose, Water Hose Vibration-Absorbing Rubber						● or 2 years
20	Adjust/Polish Engine Valve Clearance					● Adjust	● Polish
21	Check/Adjust Injection Nozzle					●	
22	Check/Adjust Injection Pump						●

(1) Oil Change

First Time	50 hour mark
2 nd or after	Every 100 hours

- ① Remove the oil plug.
- ② Loosen the oil drain plug and allow the oil to drain fully.
- ③ Reinstall the oil drain plug.
- ④ Checking the oil level by the oil level gauge, add oil into the oil filler (inlet) to fill up to the max level (about 2.0 liter max).
- ④ Reinstall the oil plug hand tight.

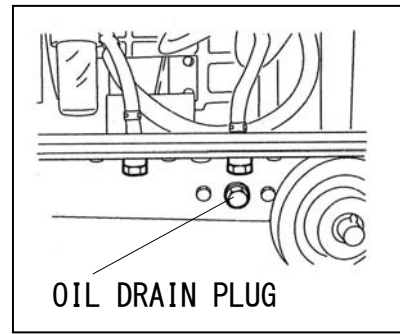

<Caution>

- Refer to 『6-1. Checking Engine Oil』 to select engine oil.
- Whenever changing oil, change the packing as well,
- Packing No. : 6C090-58961 (Kubota)

(2) Oil Filter Change

First Time	50 hour mark
2 nd or after	Every 200 hours

- ① Drain the engine oil completely, as described in 『11-1. Oil Change』 .
- ② Remove the side cover.
- ③ Loosen and remove the oil filter, using oil filter wrench.
- ④ Smear engine oil a little on the rubber gasket in a new oil filter.
- ⑤ Screw the new filter into place and tighten it by hand until the gasket contact onto the seat. Then, give it additional 『1.1/4 Turn』 to seat the filter, using an filter wrench.
- ⑥ Supply oil and install the filler cap.

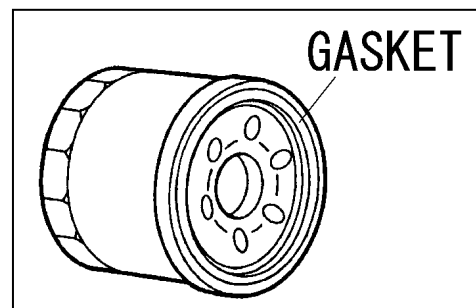
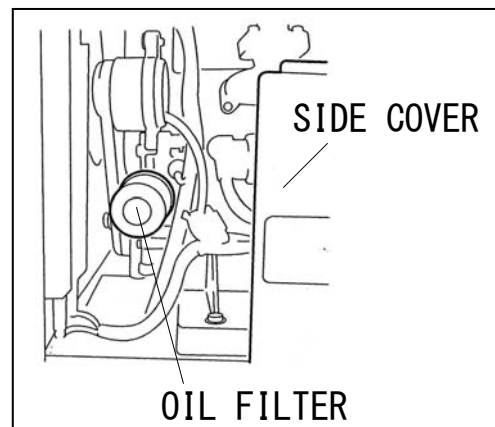

<Caution>

- If an oil filter wrench is not available to get, contact our authorized distributor or our engineering section.
- Oil Filter Part No.: 15853-32433 (Kubota)

(3) Clean/Change Air Element

Clean	1 st 50 hours and 2 nd or after every 100 hours
Change	Every 400 hours

- ① Loosen the wing bolt to remove the cleaner cap.
- ② Remove the air element.
- ③ Clean or replace the air element and reinstall in reverse order.

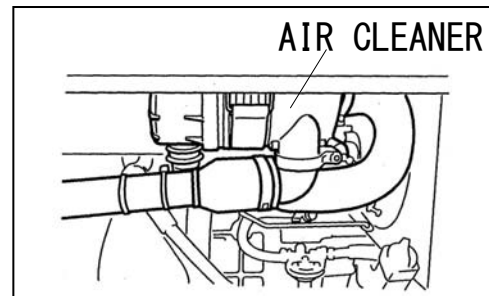

<Caution>

- Clean more frequently, if used in dusty environment.
- Air Element Part No. 67980-82632 (Kubota)

■ How to clean air element

<If the element has dried contaminants>

It may be cleaned by blowing compressed air from the inside.

<If the element has carbon or oil>

It should be replaced to a new one.

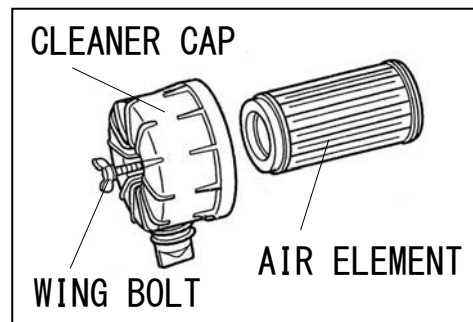

(4) Clean/Change Fuel Strainer

Clean	1 st 50 hours and 2 nd or after every 100 hours
Change	Every 400 hours

- ① Turn the fuel valve lever to [CLOSE].
- ② Unscrew the retainer ring counterclockwise, and remove the cup and the fuel element.
- ③ Discard any dust or water inside the cup, and clean the fuel element by blowing compressed air, or replace if necessary.
- ④ Reassemble it in reverse order.

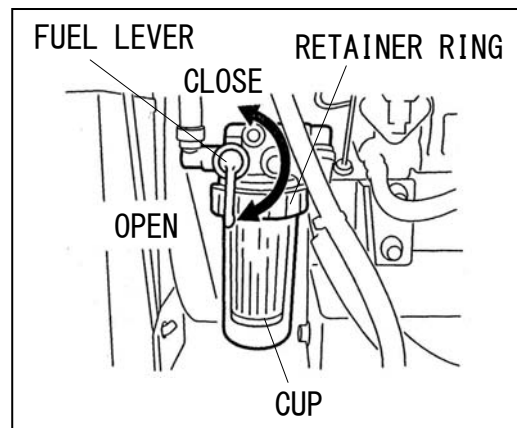

<Caution>

- Be sure to check for any contaminants the packing, whenever reinstalling the cup.
- Turn the fuel valve lever to 『OPEN』 after assembling, and check for any leak. After confirming no leak, turn the fuel valve to [CLOSE].
- Fuel Element Part No.: 16271-43561 (Kubota)

(5) Drain Water from Fuel Tank

Drain Water	Every 200 hours
-------------	-----------------

- ① Unscrew the fuel drain plug.
- ② Reinstall the drain plug, after draining water completely

<Caution>

- Change the packing, whenever changing oil.
- Packing Part No.: 6C090-58961 (Kubota)

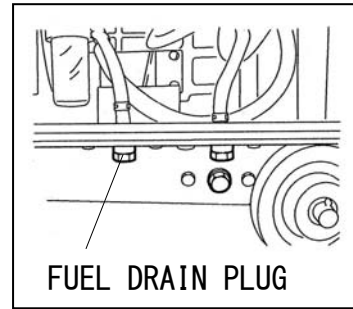

(6) Changing Coolant/Water

Change	Every 2000 hours or 2 years
--------	-----------------------------

(Total Coolant/Water Capacity: about 2.8 liter, including sub tank cap. 0.6 liter.)

- ① Remove the top plate.
- ② Remove the radiator cap.
- ③ Loosen the water drain plug.
- ④ After draining all the water, reinstall the water drain plug.

<Caution>

- Change the packing, whenever changing oil.
- Packing Part No.: 6C090-58961 (Kubota)

- ⑤ Replace all the water in the sub tank.
- ⑥ Fill the coolant/water to the neck of the water inlet.
- ⑦ Reinstall the radiator cap.
- ⑧ Install the top plate back.

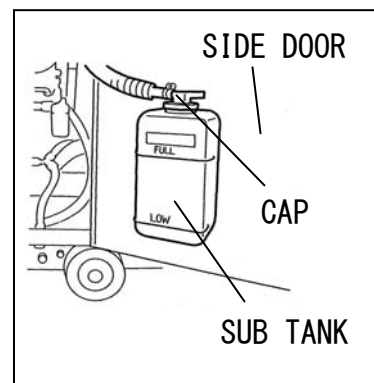
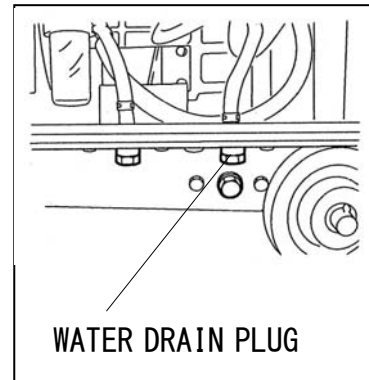
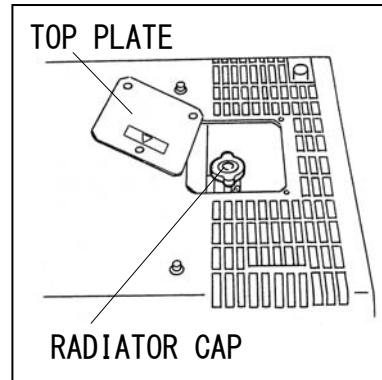

12. Long-Term Storage

Danger : Electric Shock

- Before performing any equipment check or maintenance, stop the engine, and remove the engine key. A person performing the maintenance should always keep the key.

Caution : Injuries

- Before performing any equipment check or maintenance, stop the engine, and remove the engine key. A person performing the maintenance should always keep the key.

Caution : Fire • Burns

- When checking engine, always stop the engine, and keep far away from fire. Temperature around muffler and exhaust can get extremely high. Wait until the engine cools down, before performing any checks.

If the generator/welder will not be used for more than two months, perform the following maintenance and storage procedures.

- ① Remove the battery.
- ② Change the engine oil.
- ③ Drain fuel from the fuel tank and the fuel strainer.
- ④ Clean all parts, cover the generator/welder, and keep it in the storage, away from dust and humidity.

<Caution>

- Recharge the removed battery once a month.

13. Troubleshooting

Danger : Electric Shock

- Do not operate the equipment, if the equipment or you are wet.
Before performing any equipment check or maintenance, stop the engine.

Caution : Injuries

- When performing equipment check and maintenance, always stop the engine.

Caution : Fire • Burns

- When checking engine, always stop the engine, and keep away from fire. Temperature around engine, muffler and exhaust can get extremely high. Wait until the engine cools down, before performing any checks.

Follow the guideline below, when performing any troubleshooting. If you cannot resolve the problems by this troubleshooting guide, contact the authorized distributor or our engineering section to request the repair.

Symptoms	Presumed Cause	Corrective Actions
Starter motor does not start	<ol style="list-style-type: none"> 1. Battery Weak 2. Battery Dead 	<ol style="list-style-type: none"> 1. Recharge Battery 2. Change Battery
Engine does not start	<ol style="list-style-type: none"> 1. Fuel lever to CLOSE 2. Insufficient fuel 3. Water or contaminants in fuel 4. Fuse burnt 	<ol style="list-style-type: none"> 1. Fuel lever to OPEN 2. Replenish fuel 3. Drain water or clean fuel tank , fuel strainer 4. Repair
Engine starts, but stalls immediately	<ol style="list-style-type: none"> 1. Insufficient oil 2. High water temperature 3. Charging current is not censored 	<ol style="list-style-type: none"> 1. Replenish oil 2. Keep the duty cycle of 50% [Refer to the article of Output Limitation] 3. Repair
Welding arc is weak	<ol style="list-style-type: none"> 1. The throttle at [Low Speed Welding/50Hz] 2. Wrong setting of current adjustment dial 3. Poor contacts of cables 4. Improper cable diameter 5. Insufficient contact to material 6. The total loads exceed the rated simultaneous use output limit 7. Engine output is down 	<ol style="list-style-type: none"> 1. Turn the throttle to [High Speed Welding/60Hz] 2. Turn the dial clockwise 3. Contact cables securely 4. Change cables according to [Selection-Welding Cable] 5. Contact securely 6. Refer to [Simultaneous use of Welding and AC output] 7. Clean air element
Excessive welding arc	<ol style="list-style-type: none"> 1. The setting of current adjustment dial 	<ol style="list-style-type: none"> 1. Turn the dial counterclockwise
No AC output	<ol style="list-style-type: none"> 1. The breaker to [OFF] 	<ol style="list-style-type: none"> 1. Set the breaker to [ON]
AC output is weak	<ol style="list-style-type: none"> 1. Wrong frequency 2. The current in the load exceeds the rated current 3. The loads used simultaneously exceed the rated output 	<ol style="list-style-type: none"> 1. Change the frequency to the correct one 2. Refer to the article of Output Limitation 3. Refer to [Simultaneous use of Welding and AC output]
Slow-Down does not activate	<ol style="list-style-type: none"> 1. Short circuit of welding cable 2. The power consumption of the load is 0.5A or below 	<ol style="list-style-type: none"> 1. Repair the short circuit 2. Turn the Slow-Down switch to [OFF]
Engine does not stop	<ol style="list-style-type: none"> 1. Stop solenoid disorder 2. Fuse burnt 	<ol style="list-style-type: none"> 1. Turn the fuel valve lever to [CLOSE] to stop and repair 2. Repair
Black and white smoke exhaust from the muffler	<ol style="list-style-type: none"> 1. Overloaded use 	<ol style="list-style-type: none"> 1. Keep the duty cycle of 50% and the rated output (Refer to [Output Limitation])

14. Engine Wiring Diagram

ENGINE WIRING DIAGRAM

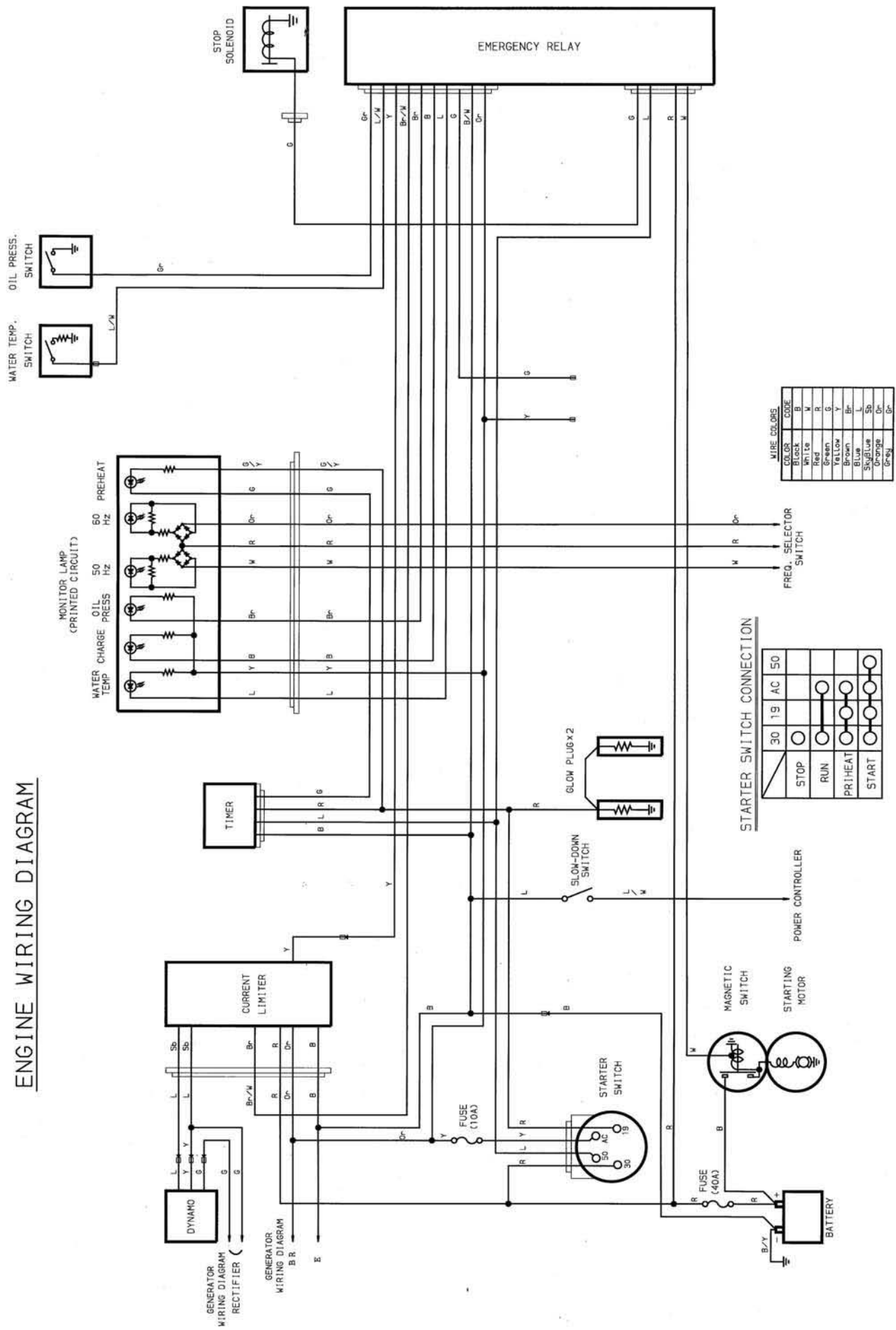

15. Generator Wiring Diagram

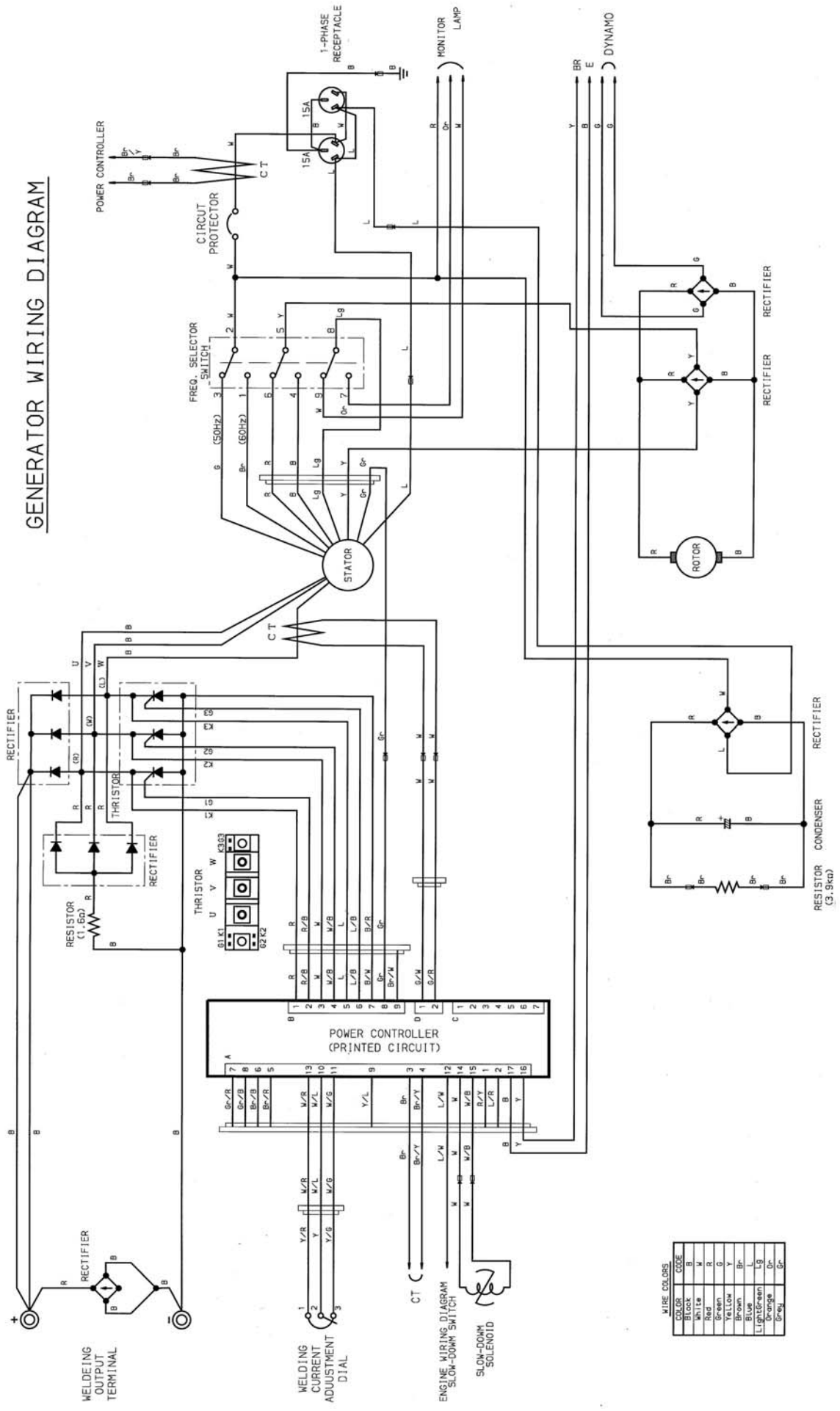

YAMABIKO CORPORATION

7-2 SUEHIROCHO 1-CHOME, OHME, TOKYO 198-8760, JAPAN
PHONE: 81-428-32-6118. FAX: 81-428-32-6145.

shindaiwa[®]